



Portable Power

PROSPAIR Series

PA415ATC_{plus}



Water Well Compressor



Portable Power

PROSPAIR Series PA415ATC_{plus}

Features:

- Compact
- Plug and Play Mounting
- Rugged enclosure with aesthetic design
- Designed for operation in an ambient of 52 deg C
- Best in Class Fuel Consumption
- Highly Reliable and Efficient Aired
- Cost effective drilling
- Low on maintenance
- Strong aftermarket support
- Resale Value

Specifications :

Performance	Unit	Details
*Free Air Delivery	CFM	1200
Drilling Pressure	PSIG	330
Unloading Pressure	PSIG	350
Compressor type	--	2 Stage
Cooling System	--	Oil Injection
Oil Capacity (Refill)	Litre	100
Max. Operating Temperature	deg C	52
Min. Operating Temperature	deg C	5
Engine	Unit	Details
Make	--	Cummins
Model	--	NTA 855 BCIII
BHP	HP	415
Strokes/No.of Cylinders	--	4 Stroke/6 Cylinders
Rated Speed	rpm	1800
Maximum RPM	rpm	1900
Idle RPM	rpm	1200
Cooling Package		Variable Fan Drive ¹ (ATC)
Dimensions	Unit	Details
Overall Length	mm	4246
Overall Width	mm	1800
Overall Height	mm	2180
Gross Weight	kg	5200

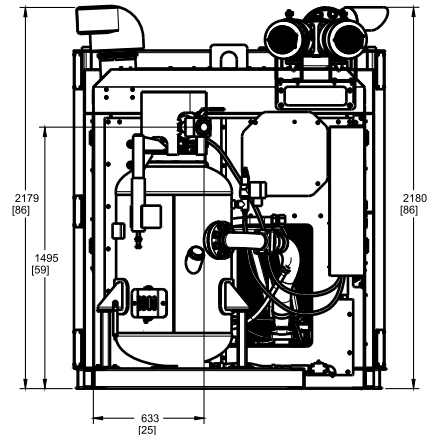
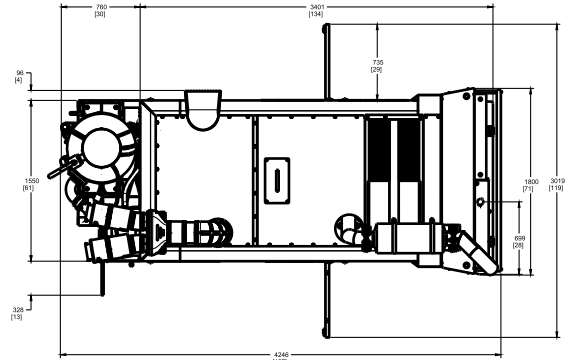
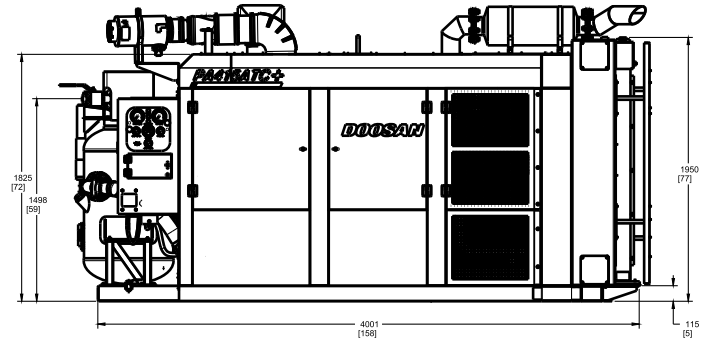

Safety

- High Air Temperature Shut down
- Low Engine Oil Pressure Shut down
- High Engine Water Temperature Shut down
- Low Hydraulic Oil Level Safety Shut down
- Hydraulic Filter Choke Alarm
- Safety Valve on separator Tank
- Safety Valve for Aired on High Pressure side

* In Accordance to ISO1217 1996 Annexure E
¹(ATC - Automatic Temperature Control)

* Disclaimer: The above specifications are liable to change due to continuous improvement process and for reference only. Doosan Infracore India Pvt.Ltd reserve the right to revise the specification or dimensions without notice.



Portable Power

Doosan Infracore India Pvt. Ltd.
 106/10-11-12, Amruthalli, Byatarayanapura,
 Bellary Road, Bangalore-560 092, India.
 Tel.No: 080-42979500 Toll Free : 1800 200 2299
 Email : marketingindia@doosan.com,
 Website : www.doosanportablepower.com

Authorized Dealer

